



Calorex Australia Pty Ltd  
ABN 38 119 660 874

17 Milgate Street  
Oakleigh South Victoria 3167

P: +61(0)3.9544 4546  
F: +61(0)3.9544 4255  
E: info@calorex.com.au  
www.calorex.com.au

## **INSTALLATION, OPERATION & MAINTENANCE INSTRUCTIONS**

### **40-50mm FIG 514 PRESSURE REDUCING VALVE**

#### **INSTALLATION:**

1. Ensure that the pipeline is free from foreign matter upstream of the valve, before installation.
2. The valve may be installed in a horizontal or vertical pipeline.
3. Mount the valve in the pipeline with the flow direction as indicated on the valve body.
4. Make sure that thread sealing products or residues do not enter the valve.

#### **COMMISSIONING:**

1. If the valve has been factory set, the valve can be put into service by introducing the fluid pressure slowly, while observing the downstream pressure for irregularities.

When the pressure has stabilised, verify that the downstream pressure is correct. If not, re-adjust the pressure by slackening the locknut and rotating the adjusting screw as required.

2. If the valve is not pre-set. To avoid the possibility of having a damaging pressure surge downstream, remove all load from the regulating spring by rotating the adjusting screw anti-clockwise until all spring load is released.

Introduce pressure to the valve. The downstream pressure should be minimal and the valve closed. Increase the loading on the regulating spring by rotating the adjusting screw clockwise until the desired pressure is reached. The adjusting screw can now be secured by tightening the locking nut.

#### **TROUBLESHOOTING:**

##### **Failure of the valve to reach the desired reduced pressure:**

1. Incorrect adjustment: re-adjust to a pressure gauge.
2. Seizing of internal parts due to grit etc. in medium: - overhaul as described below.
3. Valve undersized for application.

##### **Downstream pressure exceeding set pressure.**

1. Incorrect adjustment of regulating spring: Re-adjust as described.
2. Seizing of internal parts due to grit etc. in medium: Overhaul as described below.
3. Valve seating fouled by foreign matter: Dismantle and clean.
4. Valve seals damaged or worn: Overhaul and fit new seals as described below.



**Valve leaking externally.**

1. If leaking from bottom cap: replace 'O' ring gasket.
2. If leaking from spring-cage area: replace piston 'U' Seal.

**MAINTENANCE AND REPAIR;**

**It is recommended that all seals be replaced periodically depending upon frequency of operation.**

**To overhaul the valve.**

1. Ensure that the pressure has been released from the system, or the valve isolated and all pressure bled off.
2. Release the regulating spring load by slackening the locking nut and unscrewing the adjusting screw.
3. Unscrew and remove the spring-cage (3) using a suitable 'C' spanner. Put loose components aside for re assembly.
4. Remove the bottom cap (2) by unscrewing, using a suitable spanner if necessary.
5. Undo spindle nut (13) and withdraw the valve spindle (8) through the top of the valve body.
6. Remove retaining disc (6) from bottom of valve and replace item (7&14) disc o-ring seals.
7. Clean all parts thoroughly, replace all seals and apply Nickel or Moly based grease to moving parts.
8. Examine all parts for scuffing, wear or damage. Polish, repair or replace as necessary.
9. Re-assembly is the reverse of dismantling. See "Commissioning" for returning to service.

**For spare parts or information, contact your supplier or Calorex, providing valve serial number and size.**

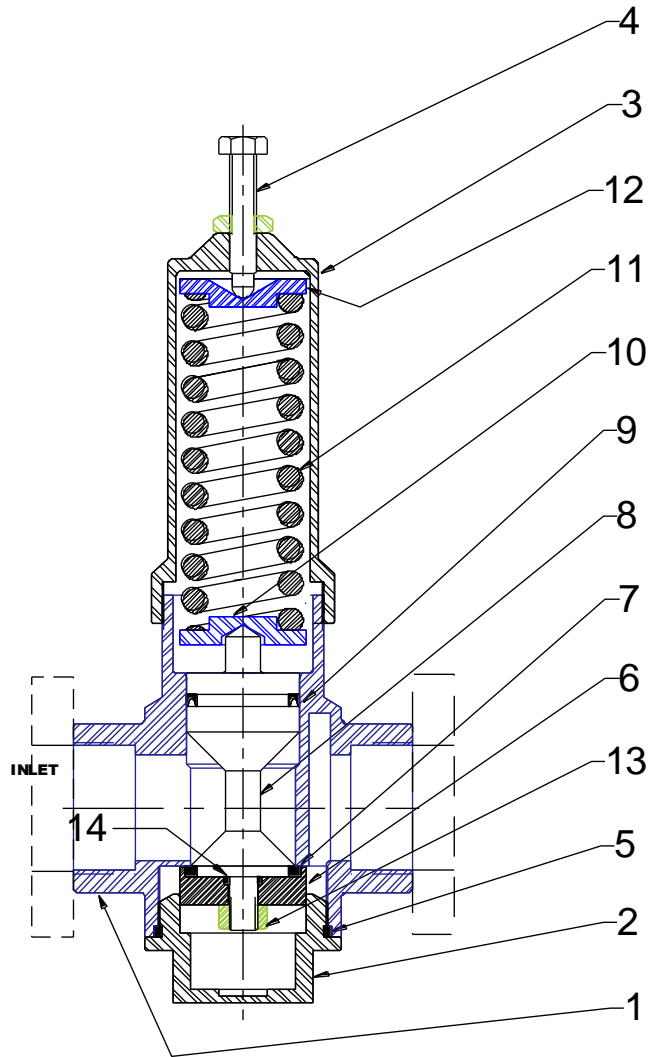

**40-50mm 'ROMA' Fig 514 Pressure Reducing Valve**

1	Body
2	Cap
3	Spring Cage
4	Adjusting Screw
5	Cap O-ring Gasket
6	Retaining Disc
7	Disc O-ring Seal
8	Valve Spindle
9	Spindle U-ring Seal
10	Lower Spring-pad
11	Regulating Spring
12	Upper Spring Pad
13	Spindle Nut
14	Spindle Seal